

***Strata*<sup>®</sup> CS**  
**Communication Server**

**Analog Telephone  
User Guide**

---

## Publication Information

Toshiba America Information Systems, Inc., Telecommunication Systems Division, reserves the right, without prior notice, to revise this information publication for any reason, including, but not limited to, utilization of new advances in the state of technical arts or to simply change the design of this document.

Further, Toshiba America Information Systems, Inc., Telecommunication Systems Division, also reserves the right, without prior notice, to make such changes in equipment design or components as engineering or manufacturing methods may warrant.

SCS-UG-ANTEL-VA  
4016183

Version A, December 2000

## © Copyright 2000

### **Toshiba America Information Systems, Inc. Telecommunication Systems Division**

All rights reserved. No part of this manual, covered by the copyrights hereon, may be reproduced in any form or by any means—graphic, electronic, or mechanical, including recording, taping, photocopying, or information retrieval systems—without express written permission of the publisher of this material.

Strata is a registered trademark of Toshiba Corporation.  
Strategy is a registered trademark of Toshiba America Information Systems, Inc.

Trademarks, registered trademarks, and service marks are the property of their respective owners.

---

# IMPORTANT SAFETY INSTRUCTIONS

**Always follow basic safety precautions** when using your telephone equipment to reduce the risk of fire, electrical shock, and injury.

- ◆ **Read and understand all instructions** in the this User Guide.
- ◆ **Read all warnings** and follow all instructions marked on the product.
- ◆ **Unplug this product from the wall outlet before cleaning.** Use a damp cloth for cleaning. Do not use liquid or aerosol cleaners.
- ◆ **Do not use the telephone near water.** For example, do not use near a bathtub, wash bowl, kitchen sink, laundry tub, swimming pool, or in a wet basement.
- ◆ **Do not place this product on an unstable cart or stand.** The product may fall causing serious damage to the product.
- ◆ **Use only the type of power source indicated on the label.** If you are not sure of the type of power supply to your home, consult your dealer or local power company.
- ◆ **Do not place any objects on the telephone line cord.** Do not locate the telephone where the line cord will be walked on.
- ◆ **Do not block or cover ventilation slots and openings** in the bottom of the telephone. The openings should never be blocked by placing the telephone on a bed, sofa, rug, or other similar surfaces. The telephone should never be placed near or over a radiator or heat register. The telephone should never be placed in a built-in installation unless proper ventilation is provided.
- ◆ **Never spill liquid on the telephone or push objects of any kind through ventilation slots.** Liquid or objects may touch dangerous voltage points or short out parts that could result in a risk of fire or electrical shock.
- ◆ **Do not disassemble this product.** Opening or removing covers may expose you to dangerous voltages or other risks. Incorrect reassembly can cause electrical shock when the product is subsequently used.
- ◆ **Do not overload outlets and extension cords.** Some telephones require AC power from an outlet. Overloading the outlets can result in the risk of fire or electric shock.
- ◆ **Avoid using a telephone during a local thunderstorm.** There may be a remote risk of electrical shock from lightning.

- ◆ **Do not use a telephone to report a gas leak in the vicinity of the leak.**
- ◆ **Unplug the telephone from the wall outlet and refer servicing to qualified service personnel** under the following conditions:
  - ◆ When the line cord is frayed or plugs damaged.
  - ◆ If liquid has been spilled into the telephone.
  - ◆ If the telephone has been exposed to rain or water.
  - ◆ If the telephone does not operate properly by following the operating instructions. (Adjust only those controls covered by the operating instructions. Improper adjustment of other controls may result in damage and will often require extensive work by a qualified technician to restore the product to normal operation.)
  - ◆ If the telephone has been dropped or the housing damaged.
  - ◆ If the telephone exhibits distinct change in performance.

**SAVE THESE INSTRUCTIONS**

# Contents

---

## Introduction

Organization .....	v
Conventions .....	vi
Related Documents/Media .....	vii

## Chapter 1 – The Grand Tour

Overview .....	1
Parts Identification .....	2
Buttons .....	3
Auto Memory .....	3
Delete .....	3
Dial .....	3
Flash .....	3
Hold .....	3
Mem Dial .....	4
Menu .....	4
Option .....	4
Pause .....	5
Redial .....	5
Speakerphone .....	6
Store .....	6
Tone .....	6
Volume .....	6

## Contents

### Chapter 2 – Installation/Set Up

## Chapter 2 – Installation/Set Up

Installation.....	7
Wall Mount Instructions .....	8
Phone Setup .....	10
Change the Settings .....	10

## Chapter 3 – Features

Pulse and Tone Dialing .....	11
Receive Calls .....	12
Answer Call Using Handset.....	12
Answer Call Using Speakerphone .....	12
Place Calls.....	12
Make Call Using Handset.....	12
Make Call Using Speakerphone .....	13
Place Call On-hold.....	13
Redial Number .....	13
Duration Counter .....	14
Automatic Memory .....	14
Data Port .....	15
Call Waiting Display.....	15
Caller ID Features .....	16
Message Light.....	16
Message Waiting .....	16
Receive Calls .....	17
Review Calls.....	17
Delete Calls.....	18
Callback .....	18
Message Error.....	19
No Data Sent.....	19
Private Calls.....	19
Unknown Calls .....	20

## Chapter 4 – Maintenance/Troubleshooting

Maintenance Information.....	21
Troubleshooting .....	22

Telephone Repair .....23

**Appendix – Telephone Commands Quick Reference**

Call Screening Menu.....26  
Call Handling Menu.....26  
Quick Call Menu .....27  
Voice Mail/Account Menu .....28  
    Logging In .....28  
    Voice Mail/Account Menu Commands .....28

**Index**.....31

## **Contents**

*Chapter 4 – Maintenance/Troubleshooting*

# Introduction

---

This guide describes how to use the Strata CS-C2210 analog telephone with Strata CS systems. The CS-C2210 model telephone covered in this guide is equipped with a Liquid Crystal Display (LCD) and speakerphone.

## Organization

This guide is divided as follows:

- ◆ **Chapter 1 – The Grand Tour** provides an overview of the phone and its feature buttons.
- ◆ **Chapter 2 – Installation/Set up** gives you instructions on installing and setting up the phone.
- ◆ **Chapter 3 – Features** covers the many features provided by the phone and gives functional descriptions of the buttons, LED lights and LCD displays.
- ◆ **Chapter 4 – Maintenance/Troubleshooting** gives general maintenance tips and solutions to common installation and set up problems.
- ◆ **Appendix – Telephone Commands Quick Reference** provides analog telephone dial pad command instructions including control buttons, Call Handling, Quick Call using \*, and Voice Messaging Menus.
- ◆ **Index**

## Conventions

Letters in [brackets] represent buttons which have Directory Numbers on them. For example:

Conventions	Description
<b>Note</b>	Elaborates specific items or references other information. Within some tables, general notes apply to the entire table and numbered notes apply to specific items.
<b>Important!</b>	<i>Calls attention to important instructions or information.</i>
<b>CAUTION!</b>	<b>Advises you that hardware, software applications, or data could be damaged if the instructions are not followed closely.</b>
<b>WARNING!</b>	<b>Alerts you when the given task could cause personal injury or death.</b>
[DN]	Represents any Directory Number button, also known as an extension or intercom number.
[PDN]	Represents any Primary Directory Number button (the extension number for the telephone).
[SDN]	Represents any Secondary appearance of a PDN. A PDN which appears on another telephone is considered an SDN.
[PhDN]	Represents any Phantom Directory Number button (an additional DN).
<b>Arial Bold</b>	Represents telephone buttons.
Plus (+)	Shows a multiple PC keyboard or phone button entry. Entries without spaces between them show a simultaneous entry. Example: <b>Esc+Enter</b> . Entries with spaces between them show a sequential entry. Example: # + 5.
Tilde (~)	Means “through.” Example: 350~640 Hz frequency range.
➤	Denotes the step in a one-step procedure.
➤	Denotes a procedure.
<a href="#">See Figure 10</a>	Grey words within the printed text denote cross-references. In the electronic version of this document (Strata DK Library CD-ROM or FYI Internet download), cross-references appear in blue hypertext.

## Related Documents/Media

**Note** Some documents listed here may appear in different versions on the CD-ROM, FYI, or in print. To find the most current version, check the version/date in the Publication Information on the back of the document's title page.

You can find additional detailed information about Strata CS features in the following companion documents:

- ◆ Strata CS General Description
- ◆ Strata CS Installation and Maintenance Manual
- ◆ Strata CS Administrator Manual
- ◆ Strata CS Client User Guide
- ◆ Strata CS Quick Reference Guide
- ◆ Strata CS Library CD-ROM
- ◆ Strata CS Application Software CD-ROM

For authorized users, Internet site FYI (<http://fyi.tsd.toshiba.com>) contains all current Strata CS documentation and enables you to view, print, and download current publications.

## **Introduction**

*Related Documents/Media*

## Overview

The Strata CS-C2210 is a multi-featured analog phone that includes programmable feature buttons, LED buttons, and an LCD display.

Features include:

- ◆ Call Waiting Caller ID – lets you see the name and number of an incoming call, even while you are on another call.
- ◆ LCD Symbols – New Call, Repeat Call, Forward Call, Toll Call and Message Waiting
- ◆ Extra-large, three-line LCD Panel with backlighting
- ◆ Programmable Area Code and Long Distance Code
- ◆ Ten Direct Dial Memory Numbers + 10 Dial Pad Memory Numbers
- ◆ Three languages – English, French and Spanish
- ◆ Electronic Hold with LED
- ◆ Frequency Shift Keying (FSK) and Stutter-dial Tone
- ◆ Tone/pulse Switchable
- ◆ Desk/wall Mountable
- ◆ 80-message Memory
- ◆ Last Number Redial
- ◆ Speakerphone
- ◆ Data port
- ◆ Flash

# Parts Identification

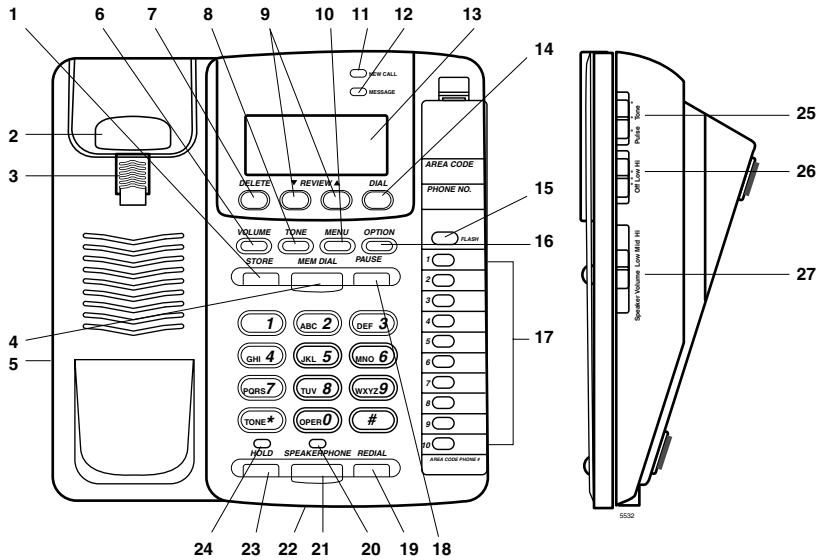

1	<b>Store Button</b>	15	<b>Flash Button</b>
2	<b>Hookswitch</b>	16	<b>Option Button</b>
3	<b>Handset Hook</b>	17	<b>Auto Memory Buttons (10)</b>
4	<b>Mem Dial Button</b>	18	<b>Pause Button</b>
5	<b>Handset Cord Jack</b>	19	<b>Redial Button</b>
6	<b>Volume Button</b>	20	<b>Speakerphone LED</b>
7	<b>Delete Button</b>	21	<b>Speakerphone Button</b>
8	<b>Tone Button</b>	22	<b>Memory Dial Index (for auto memory buttons)</b>
9	<b>Review Up/Down Buttons</b>	23	<b>Hold Button</b>
10	<b>Menu Button</b>	24	<b>Hold LED</b>
11	<b>New Call LED (Red)</b>	25	<b>Pulse/Tone Switch</b>
12	<b>Message LED (Green)</b>	26	<b>Ringer Switch (Off/Low/Hi)</b>
13	<b>LCD Display</b>	27	<b>Speaker Volume Switch (Off/Mid/Hi)</b>
14	<b>Dial Button</b>		

# Buttons

See “[Parts Identification](#)” on page 2 for button locations.

## Auto Memory

**Auto Memory** enables you to store up to ten phone numbers (15-digits maximum each) in memory using the 10 **Auto Memory** buttons at the right of the phone.

## Delete

When reviewing calls in memory, press **Delete** to erase the call displayed on the LCD. Pressing **Delete** for three seconds or more deletes all calls in memory.

## Dial

When reviewing incoming stored calls on your phone’s LCD, you can press **Dial** to automatically dial the displayed phone number. See “[Callback](#)” on page 18 for details.

## Flash

This telephone provides a line break signal for accessing Private Automatic Branch eXchange (PABX) service or for convenient use of Call Waiting from your local telephone company. If you have Call Waiting service, you can alternate the Call Waiting function per the following instructions.

1. While having a conversation, another party calls and you hear a tone.
2. Press **Flash** once and release. The first conversation is placed on-hold and the second call can be answered.
3. Press **Flash** again and release. You can resume your conversation with the first caller and the second call is placed on-hold.

## Hold

**Hold** enables you to place a call on-hold and retrieve the call when you are ready to resume the conversation. The Hold LED lights up when a call is on-hold.

## Mem Dial

When you store a phone number on a dial pad button, you must first press **Mem Dial** and then the dial pad button in order to dial the stored number.

## Menu

After you have set up the phone completely for the first time, use **Menu** to review or reprogram the Language, Area Code or LDS Code. See “[Phone Setup](#)” on page 10.

## Option

**Option** enables you to change the format of the display number. The available formats are:

- ◆ 7-digit 7-digit telephone number.
- ◆ 10-digit 3-digit area code + 7-digit telephone number.
- ◆ 11-digit 1-digit long distance code + 3-digit area code + 7-digit telephone number.

### Local Calls (7-digit number)

- ◆ Pressing **Option** once, changes it to a 10-digit format (your area code + 7-digit number).
- ◆ Pressing **Option** twice, changes it to an 11-digit number (1 + your area code + 7-digit telephone number).
- ◆ Pressing **Option** three times, changes it back to the original 7-digit telephone number.

For example: Your area code is 205 and you are reviewing telephone number 785-2883. When the desired format of the telephone number is reached, press **Dial** to dial the display number.

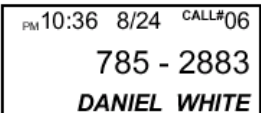
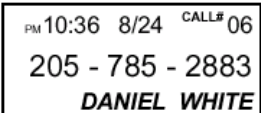
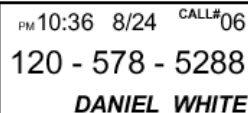
Original	Press Option button once	Press Option button twice
785-2883	(205) 785-2883	1 + (205) 785-2883
		

**Note** Since the LCD can only display 10-digit telephone numbers, when you change the format to 11-digits, only the first 10 digits can display, but the full 11-digits are dialed if you press **Dial**.

### Long Distance Call (10-digit number)

- ◆ Pressing **Option** once, changes it to an 11-digit number (1+ 3-digit area code + 7-digit telephone number).
- ◆ Pressing **Option** twice, removes the 3-digit area code and changes the display to 7-digit telephone number.
- ◆ Pressing **Option** three times, changes it back to the original 10-digit number.

For example: your own area code is 205, and you are reviewing telephone number 914-656-5756. When the desired format of the telephone number is reached, press **Dial** to dial the displayed number.

Original	Press Option button once	Press Option button twice
(914) 656-5756	1+(914) 656-5756	656-5756
<div style="border: 1px solid black; padding: 5px;">                     PM 8:29 8/24 CALL# 06                      914 - 656 - 5756                      SMITH JOHN                 </div>	<div style="border: 1px solid black; padding: 5px;">                     PM 8:29 8/24 CALL# 06                      191 - 465 - 6575                      SMITH JOHN                 </div>	<div style="border: 1px solid black; padding: 5px;">                     PM 8:29 8/24 CALL# 06                      656 - 5756                      SMITH JOHN                 </div>

### Pause

**Pause** enables you to insert a 3.6-second pause in the dialing sequence. This is particularly useful if you are connected to a PABX system where you must dial an access code (usually **9**) to obtain an outside line.

Press **Pause** once and release at any point in the dialing sequence where a pause is desired. The **Pause** can be pressed more than once to create a longer pause.

### Redial

By pressing **Redial**, the last phone number dialed (31-digits maximum) is automatically redialed.

## Speakerphone

**Note** AC Adaptor must be used to ensure proper function.

**Speakerphone** enables you to make and receive calls without lifting the handset. Press **Speakerphone** to toggle the speaker On/Off. The Speakerphone LED indicates the status of the speaker.

See [“Answer Call Using Speakerphone” on page 12](#) and [“Make Call Using Speakerphone” on page 13](#) for details.

## Store

**Store** enables you to store up to 10 phone numbers (15-digits maximum each) in memory using an **Auto Memory** button (**1**, **2**, **3**, or **10**) and another 10 phone numbers using a dial pad button (**1**, **2**, **3**, or **0**). See [“Store Number in Memory” on page 14](#).

## Tone

If the **Pulse/tone Switch** is set to the Pulse position, and you want to make a tone entry (e.g., telephone number into pager) after pulse dialing, press **Tone** once, then dial the number. The number dialed is changed to tone dialing automatically without setting the **Pulse/tone Switch** to the Tone position.

## Volume

A built-in amplifier feature enables you to increase the listening volume in the receiver of the handset when speaking with your party. When needed, press **Volume** to achieve three different levels. The volume goes back to normal after you hang up the handset.

# Installation/Set Up

# 2

This chapter covers desk and wall mount installation instructions, phone setup procedures and procedures for changing the factory settings.

## Installation

1. **Connect Adapter.** Plug the large part of the adapter into the wall outlet and the adapter tip to the jack at the rear side of phone. (Use only 9VDC, 200mA, center positive Class 2 adapter.)
2. **Connect Telephone Line Cord.** Use the new line cord to connect the phone jack of your new caller ID phone to the modular wall jack (see figure below).

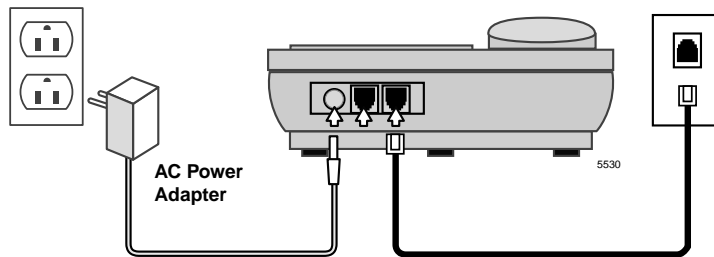

## Installation/Set Up

### Wall Mount Instructions

3. Check bracket is in correct position (shown at right).

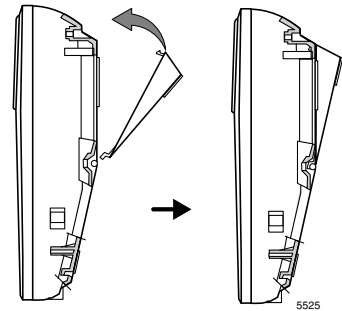

**Desk**

4. Check handset hook is in correct position (shown at right).
5. Set up phone. See [“Phone Setup” on page 10](#) for instructions.
6. Locate phone. Place the phone on a flat table or mount it on the wall. If you desire to place it on a wall, use the wall mount bracket and short line cord supplied to accomplish the wall mounting. (See [“Wall Mount Instructions”](#) below.)

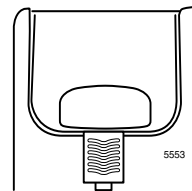

**Handset Hook  
Desktop Position**

## Wall Mount Instructions

1. Install wall mount bracket in wall mount position (shown at right).

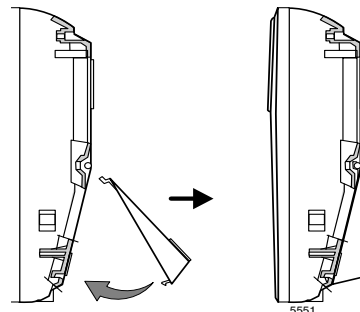

**Wall**

2. Route cords. Connect the adapter and the line cord (shown below).

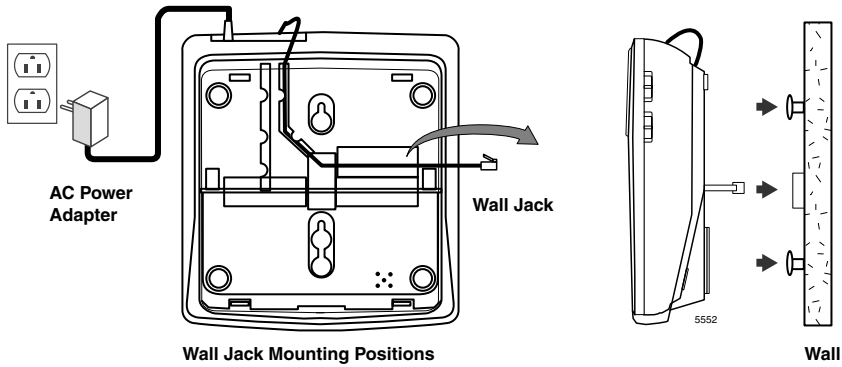

3. Push out the handset hook and reattach in opposite direction for the wall mount position (shown at right), plug the coiled cord into the handset, and then plug the other end of the cord into the base.



4. Place the handset on the base (shown at right).
5. Set up phone. See [“Phone Setup” on page 10](#) for instructions.

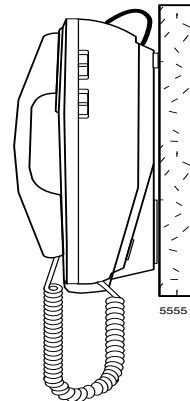

## Phone Setup

The following are the factory settings for your telephone: Language – English, LCD Contrast – 1, Area Code – no setting, LDS Code – 1

### Change the Settings

- ◆ [SET LANGUAGE] displays (shown right). Press **Review Up** (▲) to select the language. E - English, F - French, S - Spanish, and then press **Dial** to confirm the selection.

E  
SET LANGUAGE

- ◆ When [LCD CONTRAST] appears (shown right), press **Review Up** (▲) button to set the contrast darker, and then you can press **Review Down** (▼) button to set the contrast back to the preset.

2  
LCD CONTRAST

- ◆ When [SET AREA CODE] appears (shown right), use **Review Up** (▲) button and **Review Down** (▼) button to set your local area code.

- - -  
SET AREA CODE

**Review Up** (▲) button to change the digit from  
-, 0, 1, 2, -9

**Review Down** (▼) button to move to the next digit.

When you are finished setting the local area code, press **Dial**.

- ◆ When [SET LDS CODE] appears (shown right), press **Review Up** (▲) to change the long distance code from -, 0, 1, 2, -9. When you are finished, press **Dial** (display shown at right). You are ready to receive calls.

1  
SET LDS CODE

**Note** The LDS code for the USA or Canada must be set to 1.

- ◆ The time and date are automatically set when a Caller ID (CID) number is received. The phone keeps the current time accurately, and is updated each time a CID number is received.

TOTAL CALLS 00

After you have set up the phone completely for the first time, use the **Menu** button to review or reprogram the Language, Area Code or LDS Code.

## Pulse and Tone Dialing

1. If your telephone line accepts touch-tone dialing, set the **Pulse/tone Switch** to the Tone position.
2. If your telephone line requires rotary (pulse) dialing, set the **Pulse/tone Switch** to the Pulse position.
3. If you are unsure which system you have, set the switch to the Tone position. Lift the handset. When you get a dial tone, dial a telephone number. If the dial tone continues, move the switch to Pulse, and then dial the telephone number again.

**Note** In order for the Caller ID callback to work (see [“Caller ID Features” on page 16](#)), you must set the **Pulse/tone Switch** to the Tone position.

## Receive Calls

You can answer a call using either the phone's handset or speakerphone. The New Call LED at the top of the phone lights up to let you know when new calls are received.

### Answer Call Using Handset

1. Be sure the **Ringer Switch** is set to the Hi or Low position.
2. When the phone rings and the LCD displays the Caller ID information, lift the handset and begin your conversation.
3. Set the **Ringer Switch** to the Off position when you do not want to be interrupted by the phone ringing. Remember to set the ringer switch back to Hi or Low when you want to receive calls again.

### Answer Call Using Speakerphone

1. When the phone rings and the LCD displays the Caller ID information, press and release **Speakerphone** and talk normally into the built-in microphone from a distance of five-six inches.
2. You can adjust the volume of the caller's voice by sliding the **Speaker Volume Switch** on the right side of the phone.
3. After the conversation has finished, press **Speakerphone** to hang up.

## Place Calls

You can place a call using either the handset or speakerphone.

### Make Call Using Handset

1. Lift the handset and wait for a dial tone.
2. Dial the telephone number you wish to call. The number appears in the LCD.

## Make Call Using Speakerphone

1. Press and release **Speakerphone**.
2. When you hear a dial tone, dial the number or press **Auto Memory** just as you would on any other push-button telephone. The number appears in the LCD.
3. When your party answers, adjust the sound level by sliding the **Speaker Volume Switch** located on the right side of the phone.
4. After the conversation has finished, press **Speakerphone** to hang up.

### Notes

- If you wish to switch from speakerphone to handset, simply lift the handset.
- If you wish to switch from handset to speakerphone, press and release **Speakerphone** and then hang up the handset.

## Place Call On-hold

1. To place a call on-hold, press **Hold** and hang up the handset. The Hold LED lights and remains lit until you resume your conversation.
2. To resume your conversation, lift the handset or that of any extension phone on the same line or press and release **Speakerphone**. The Hold LED goes out and your call can continue.

## Redial Number

1. If the number you dialed is busy, or you want to call the last number dialed again, lift the handset, or press and release the hookswitch for a new dial tone.
2. Press **Redial**. The number appears in the LCD display.
3. The last number called (31-digits maximum) is automatically redialed.

## Duration Counter

A built-in counter starts counting for your reference six seconds after you lift the handset or six seconds after you dial a telephone number.

## Automatic Memory

You can store up to ten phone numbers (15-digits maximum each) in memory using the **Auto Memory** buttons (**1**, **2**, **3**, or **10**) and another ten phone numbers using dial pad buttons (**1**, **2**, **3**, or **0**).

### Store Number in Memory

1. Press **Store**, [MEMORY STORING] displays.
2. Dial the telephone number (15-digits maximum) you want to store in memory.

**Note** The memory locations can be chained together to store numbers of longer length.

3. Press **Store** again.
4. Press the desired memory location.
  - To store number on an **Auto Memory** button (located on right-hand side of base), press **1**, **2**, **3**, or **10**  
...or to store in a dial pad memory location, press one of the dial pad buttons (**1**, **2**, **3**, or **0**).
5. Use the pull-out Memory Dial Index to write in the name and location (button) where it is stored.

## Dial Phone Number in Memory

1. Lift the handset and wait for a dial tone.
2. Press any memory location.
  - To dial a number stored on an **Auto Memory** button (located on right-hand side of base), press the desired **Auto Memory** button (**1**, **2**, **3**, or **10**)  
  
...or to dial a number stored in a dial pad memory location, press **Mem Dial** first, then the desired dial pad button (**1**, **2**, **3**, or **0**).
3. The number displays and dials automatically.

## Data Port

This is a connection which is in parallel with the telephone line. It enables the connection of a device such as a modem, Caller ID, or an answering machine.

## Call Waiting Display

With Call Waiting Caller ID, a tone alerts you there is a new call when you are on an existing call, and lets you know who the caller is before you answer it. The call waiting information is shown on the phone's display.

The CALL WAITING (CW) symbol flashes for 16 seconds along with the telephone number and name of the person who is on Call Waiting. Press **Flash** to put the existing call on-hold and answer the new call.

No matter whether you answer the call or not, the Call Waiting Caller ID stores the call information for future reference.

**Note** Make sure you have subscribed to both Call Waiting Caller ID and Caller ID service from your local telephone company. If you only have Caller ID service, the phone works for Caller ID only.

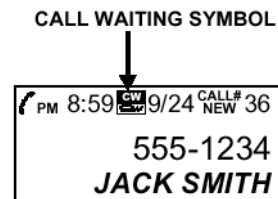

# Caller ID Features

## Message Light

The Message LED flashes to alert you to check your voice mail on the Strata CS for your new messages.

The Message LED also monitors the phone's status. When the phone is in use, the Message LED is on continuously. If the LED is flashing quickly, it means the phone is ringing. If it is not ringing and the light is flashing, the phone has experienced a power outage.

## Message Waiting

This phone's Message Waiting detection is for both FSK and Stutter-dial Tone hone systems.

### If Your Service Is FSK

1. The Message LED flashes and [MESSAGE WAITING] displays on the LCD for 20 seconds when a message waiting On signal is received from the Strata CS.
2. The Message LED turns off and [MSG WAITING OFF] displays for 20 seconds if the message waiting off signal is sent from the Strata CS.

### If You Have a Stutter-dial Tone System

1. This phone checks your line for a stutter-dial tone every time you hang up or each time a call goes unanswered. The Message LED flashes when there is a message waiting.
2. You may experience some delay in seeing the Message LED light up even though there are messages in your voice mailbox. This delay is due to regulatory matters and does not indicate a problem with the phone.

This phone may not be activated or deactivated under certain conditions. For example, when you retrieve your message from an outside phone (not your own telephone number), the Message LED may not be canceled when you return home. If you experience this situation, pick up the receiver and hang up. The Message LED cancels.

## Receive Calls

- When the telephone is not in use and a new call is received, the LCD displays **NEW**, the phone number, the caller's name, and time and date of the call for the first 20 seconds. The **RPT** (repeat) symbol appears if the call has come in more than once.
- After 20 seconds with no activity, the display defaults to the Standby screen and remains on until another call is received or a button is pressed. The Standby screen displays the total number of calls stored and how many new calls have not been reviewed.

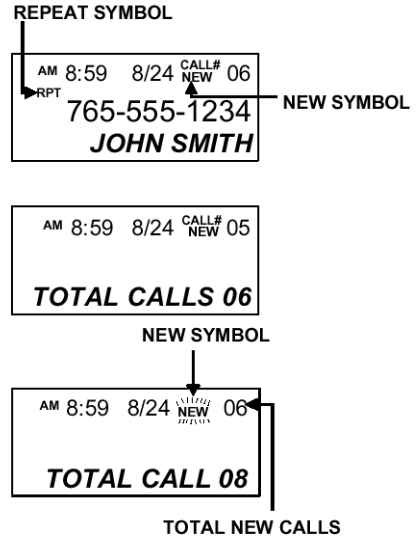

## Review Calls

- When you have new incoming calls, the **NEW** symbol flashes on the Standby screen. Next to the **NEW** symbol is the total number of new calls. Press **Review Up** (▲) or **Review Down** (▼) to review the incoming stored calls.
- The **NEW** symbol attached to each call is removed after you review the call.
- If the **NEW** symbol is still flashing when the display goes back to the Standby screen, there are new calls that you have not yet reviewed.
- The reviewed number can be stored into any of the **Auto Memory** buttons or dial pad memory locations by pressing **Store** first, then one of the memory buttons.
- When you have reached the end of the call records, [-END OF LIST-] displays, confirming there are no more calls stored.



**Note** If the telephone number received is more than 10 digits, the LCD only stores the first 10 digits in memory.

## Features

### Caller ID Features

## Delete Calls

### Delete individual Call

- When reviewing calls, press **Delete** once. The display erases each line, one at a time, and the remaining records are renumbered.



### Delete All Calls

- When reviewing calls, press and hold **Delete** for more than three seconds. When [DELETE ALL] displays, press **Delete** again to confirm the deletion of all records. [-NO CALLS-] displays to show there are no calls stored in memory.

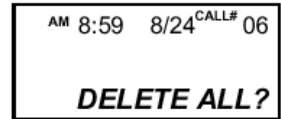

## Callback

When reviewing received calls, there are two ways using **Dial** to dial the telephone numbers shown on the display.

1. With the handset in its cradle (on-hook), press **Dial**. [PICKUP PHONE...] displays in the LCD to ask you to pick up the handset. Once you pick up the handset, the number is dialed.
2. If you pick up the handset, review the calls, and press **Dial**, the displayed number is dialed immediately.

HANDSET SYMBOL

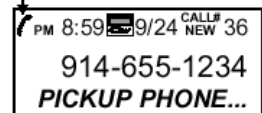

**Note** The HANDSET displays in the LCD when the handset is picked up.

If [SET AREA CODE] appears prior to [PICKUP PHONE...] or dialing, it means you have not programmed the local area code. Please hang up the telephone and program the area code.

1. If a local call (a telephone number with the same area code as you set) is reviewed and its 7-digit number displayed, press **Dial** to dial the number displayed.

2. If a long distance call (a telephone number with a different area code than you set) is reviewed and its 10-digit number (3-digit area code + 7-digit telephone number) is displayed, press **Dial** to dial the number displayed.

## Message Error

[-ERROR-] displays (shown right) if your phone receives a call that has an error in the transmission or reception.

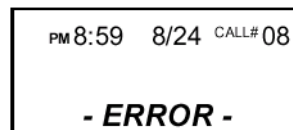

## No Data Sent

[-NO DATA SENT-] displays (shown right) if there is no caller ID (CID) number sent from the telephone company while ringing.

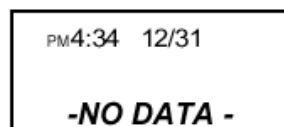

## Private Calls

If the caller has exercised the option to block his number from being sent, [PRIVATE NUMBER] and his name alternately displays on the screen when this information is received.

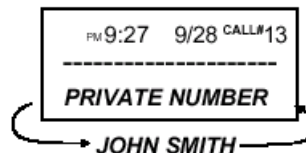

If the caller has exercised the option to block his name from being sent, [PRIVATE NAME] and his telephone number displays on the screen.

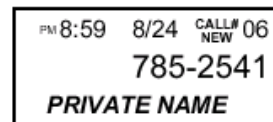

If the caller has exercised the option to block his name and number from being sent, then [PRIVATE CALLER] displays on the screen.

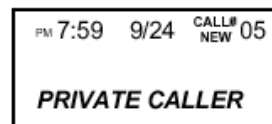

## Features

### Caller ID Features

## Unknown Calls

When the telephone company is unable to provide the caller's telephone number, [UNKNOWN NUMBER] and the caller's name alternately display on the screen.

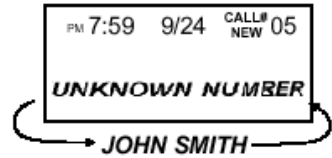

When the telephone company is unable to provide the caller's name, [UNKNOWN NAME] and telephone number displays on the screen.

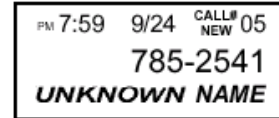

When the telephone company is unable to provide the caller's name and number, [UNKNOWN CALLER] displays on the screen.

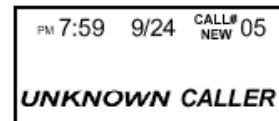

## Maintenance Information

- ◆ Treat your telephone equipment with care for trouble-free performance.
- ◆ Avoid dropping the handset. Carefully place the handset on-hook after use.
- ◆ Avoid putting near heating appliances and devices that generate electrical noise (e.g., motors and fluorescent lamps).
- ◆ Clean your telephone equipment with a damp cloth. Stains may be removed with a mild soap. Do not use liquid or aerosol detergents or cleaning agents.
- ◆ Do not expose to direct sunlight or moisture.
- ◆ Retain the original package in case you need to ship it at a later date.

# Troubleshooting

**Note** If you have any problems with your telephone equipment service, determine if the problem is with your phone or the telephone company lines. Before calling the telephone company, be aware that they may charge you for a service call if the problem is caused by your telephone equipment.

The following table provides solution(s) to common installation and setup problems.

Problem	Solution(s)
<b>Phone does not ring</b>	<ul style="list-style-type: none"> <li>◆ Hi/low/off <b>Ringer Switch</b> is set to Off position.</li> <li>◆ Line cord is disconnected at telephone outlet or at telephone end.</li> <li>◆ Phone is off-hook. Make certain the hookswitch is depressed when the handset is in the cradle.</li> <li>◆ <b>Speakerphone</b> LED is On. Turn Off speakerphone.</li> </ul>
<b>No dial tone</b>	<ul style="list-style-type: none"> <li>◆ Check to make sure wire is connected at telephone jack or at wall jack.</li> <li>◆ Test the telephone in a different wall jack. If it works, the first jack may be defective.</li> </ul>
<b>Have dial tone but cannot dial out</b>	<ul style="list-style-type: none"> <li>◆ Check if the <b>Pulse/tone Switch</b> is at the correct position.</li> </ul>
<b>Redial button does not function</b>	<ul style="list-style-type: none"> <li>◆ The telephone may have been momentarily disconnected from the telephone jack.</li> </ul>
<b>Blank screen</b>	<ul style="list-style-type: none"> <li>◆ Check if the adapter is connected properly.</li> </ul>
<b>Caller IDs do not display on LCD</b>	<ul style="list-style-type: none"> <li>◆ Verify that you have subscribed to the appropriate service (Caller ID and Call Waiting Caller ID) from your telephone company. If you only subscribed to the Caller ID service this phone will not display the call waiting caller ID information.</li> </ul>
<b>No caller information displays when hearing call waiting audio sound</b>	<ul style="list-style-type: none"> <li>◆ Verify that you have subscribed to the Call Waiting Caller ID service from your telephone company.</li> </ul>

Problem	Solution(s)
<b>Message error happens frequently</b>	<ul style="list-style-type: none"><li>◆ Caller information was not transmitted properly. Check with your telephone company to see if there is a problem with your phone line.  Since our special design will always retain your stored call records, we encourage you to disconnect all the telephone cords and adapter; and then reinstall the phone step-by-step per this instruction manual before you ask for service.</li></ul> <p><b>Note</b> The call records are not erased when the adapter is disconnected. A special E2PROM design enables the phone to always retain your stored call records after you disconnect the adapter.</p>

## Telephone Repair

Do not attempt to repair this product yourself. Call your Authorized Dealer for all repairs.



# Appendix – Telephone Commands Quick Reference

---

This appendix provides a quick reference to the Strata CS Telephone Commands. For more instructions on using Strata CS over the phone, see Chapters 3 through 6 in the *Strata CS Client User Guide*.

**Important!** *You can preprogram any of the Call Handling buttons, Quick Dial commands, or Voice Mail/Account commands described in this appendix as speed dial buttons using the **Auto Memory** buttons on your analog phone. See “Automatic Memory” on Page 14 for instructions.*

**Note** From within any Telephone Commands menu, you can press \* to return to the higher level menu.

## Call Screening Menu

If you have verbal call screening turned on, you are offered the following options when you answer an incoming call, either by picking up the phone or pressing **Flash** after hearing the call waiting beep.

Table 1 Call Screening Commands

Press	Description
<b>1</b>	Connect to the caller.
<b>2</b>	Send the caller to your voice mail.
<b>3</b>	Send the caller to voice mail and monitor the message being left. Press <b>Flash 1</b> to pick up the call in mid-message.
<b>4</b>	In call waiting situations, create a conference call with your current call and the new one.
<b>Hang up</b>	Send the caller to the next step on your routing list. Unless you've changed your routing list, the next step is your voice mail, so hanging up is the same as pressing <b>2</b> .

## Call Handling Menu

As soon as you press **Flash** to put a call on hold, you'll hear a context-sensitive menu of call handling options. The caller does not hear these menu prompts. At any time while listening to the prompts, you can press **Flash** again to reconnect to the caller.

Table 2 Call Handling Commands

Press	Description (With a call on the line, press Flash, then)
<b>1</b>	Transfer the call
<b>2</b>	Send the call to voice mail
<b>3</b>	Disconnect from the call
<b>4</b>	Reconnect to the call

Table 2 Call Handling Commands *(continued)*

Press	Description (With a call on the line, press Flash, then)
<b>5</b>	Create a conference call
<b>6</b>	Park the call
<b>7</b>	Silent hold (stops menu until next keypress)
<b>8</b>	Send a Flash to Centrex/PBX service beyond Strata CS
<b>#</b>	Get a dial tone (start another call)
<b>Flash</b>	Reconnect to the call

## Quick Call Menu

When you press \* from a dial tone, you are offered the following options for placing and answering calls:

Table 3 Quick Dial Commands

Press	Description
<b>*0</b>	Hear your phone's station ID and extension.
<b>*66</b>	Redial the last call you placed.
<b>*69</b>	Dial the phone number of your last incoming call.
<b>*70</b>	Disable call waiting for the next call.
<b>*91</b>	Answer another ringing phone. Enter the extension of the phone to answer.
<b>*92</b>	Retrieve a parked call.
<b>*93</b>	Dial a Strata CS user by name.
<b>*95</b>	Manage your calls on hold.
<b>*96</b>	Log off from remote session. Only available at a dial tone when logged in from a remote phone.

## Voice Mail/Account Menu

The Voice Mail/Account menu lets you listen to your voice mail, send messages to other users' voice mail, and change your Strata CS account settings. You need to log in to access this menu.

### Logging In

1. To log in to the Voice Mail/Account menu, pick up the phone and enter **#**, **<your extension>**, **#**, **<your password>**, and **#**.
2. Enter **#**, **#**, **<your password>**, and **#** when logging in from your own Strata CS phone.

**Note** Your extension does not need to be entered.

If your voice mailbox is almost full when you log in, you are given the option to empty your Deleted folder. Messages in the Deleted folder count against your total space. For more information, see [“Voice Mailbox Size” on Page 101](#).

### Voice Mail/Account Menu Commands

Table 4 Summary of Voice Mail/Account Menu Commands

Press	Command Number and Name		
<b>1</b>	<b>Voice messages (Inbox folder)</b>		
<b>2</b>	<b>Voice messages (Saved folder)</b>		
	<b>1</b> Replay	<b>2</b> Next message	<b>3</b> Delete/Undelete message
	<b>41</b> Reply	<b>42</b> Forward	<b>43</b> Call back
	<b>5</b> Previous message	<b>6</b> Save	<b>7</b> Rewind
	<b>8</b> Undelete all	<b>9</b> Fast Forward	<b>#</b> Skip message preamble; skip rest of message
<b>3</b>	<b>Send voice message</b>		
	<b>1</b> Send	<b>2</b> Review	<b>3</b> Re-record
	<b>4</b> Append	<b>5</b> Mark Urgent	<b>6</b> Mark Private
	<b>*</b> Cancel		

**Table 4** Summary of Voice Mail/Account Menu Commands *(continued)*

Press	Command Number and Name		
<b>4</b>	<b>Manage greetings</b>		
	<b>1</b> Replay	<b>2</b> Next greeting	<b>3</b> Make active
	<b>4</b> Re-record	<b>5</b> Revert	<b>6</b> Record new greeting
	<b>7</b> Delete		
<b>5</b>	<b>Call forwarding</b>		
	<b>1</b> To this extension	<b>2</b> To internal	<b>3</b> To external
	<b>4</b> Cancel forwarding	<b>5</b> Query forwarding	<b>6</b> Toggle standard call rules
<b>6</b>	<b>Account preferences</b>		
	<b>1</b> Do Not Disturb	<b>2</b> Record voice title	<b>3</b> Change password
<b>7</b>	<b>Have Strata CS hang up</b>		
<b>#</b>	<b>Dial tone to start another call</b>		

**Note** Option 7 is only available when logging in from an outside line.

## Appendix – Telephone Commands Quick Reference

*Voice Mail/Account Menu*

# Index

---

## A

about this book  
    conventions, [vi](#)  
    related documents, [vii](#)  
auto memory, [3](#), [14](#)

## B

buttons, [3](#)  
    auto memory, [3](#)  
    delete, [3](#)  
    dial, [3](#)  
    flash, [3](#)  
    hold, [3](#)  
    mem dial, [4](#)  
    menu, [4](#)  
    option, [4](#)  
    pause, [5](#)  
    redial, [5](#)  
    speakerphone, [6](#)  
    store, [6](#)  
    volume control, [10](#), [17](#)

## C

call forwarding  
    using via telephone commands, [28](#)  
call handling  
    menu, [26](#)  
call screening  
    menu, [26](#)  
call waiting display, [15](#)  
callback, [18](#)  
caller ID features, [16](#)  
change settings, [10](#)

## D

data port, [15](#)  
delete calls, [3](#), [18](#)  
dial, [3](#)  
duration counter, [14](#)

## F

flash, [3](#)

## H

hold, [3](#)

**I**

installation, 7

**L**

logging in

to the voice mail/account menu, 28

using telephone commands, 28

**M**

maintenance information, 21

mem dial, 4

menu, 4

message error, 19

message light, 16

message waiting, 16

**N**

no data sent, 19

**O**

option, 4

**P**

parts identification, 2

pause, 5

phone setup, 10

place call on-hold, 13

place calls, 12

private calls, 19

pulse and tone dialing, 11

**R**

receive calls, 12, 17

redial number, 5, 13

review calls, 17

**S**

safety instructions, 3

speakerphone, 6

store, 6

**T**

telephone commands

call handling commands, 26

call screening, 26

menus, 26

quick dial, 27

voice mail/account menu, 28

telephone repair, 23

troubleshooting, 22

**U**

unknown calls, 20

**V**

voice mail

account menu, 28

volume, 6, 10, 17

**W**

wall mount instructions, 8